

# **TITANIUM<sup>®</sup>**

## **Flip Axle & Flexible Stinger**

*Replacement Parts, Service Manual  
and Operating Instructions*



# **TOWMASTER<sup>®</sup>**

**The Standard for the Road Ahead!**

[towmaster.com](http://towmaster.com)





A forward from Towmaster Trailers to our valued customers and dealers.

In this manual you will find service information and replacement parts for your current Towmaster trailer. We have put forth our best effort to provide you with common operations and replacement part information. However, Towmaster Trailers builds many custom trailers for various customers and cannot guarantee that your trailers features are outlined in this manual. If you encounter this problem please contact your dealer. If they cannot be of assistance please feel free to call our Parts Department.

To ensure a more productive call have your trailer's VIN number (serial number) ready as that will be needed to locate your correct replacement parts and answer your technical questions. The team here at Towmaster Trailers will make every effort to get you back up and running and keep your ownership as trouble free as possible.

# Titanium Series Flip Axle & Stinger

## Limited Warranty

**Current and complete warranty details are available at [Towmaster.com](http://Towmaster.com).**

### **Customer Registration Required**

**Federal regulations require motor vehicle manufacturers to maintain a record of original owners of their equipment. Our warranty registration fulfills this requirement. Please make every effort to complete this document and send it in.**

Manufacturer reserves the right to modify, without notice, specific designs and specifications as deemed advisable on the trailers described herein without obligation in regards to trailers previously sold. The manufacturer also reserves the right to discontinue any model or models without obligation in regards to trailers previously sold. Written warranty covers each trailer. No other warranty expressed or implied is made. Warranty on tires and brakes through original manufacturer. All dimensions approximate.

## Table Of Contents

1.0 OPERATIONS	Pg. 6
2.0 MAINTENANCE	Pg. 10
3.0 SCHEMATICS	Pg. 13
4.0 REPLACEMENT PARTS	Pg. 18

CONTENTS

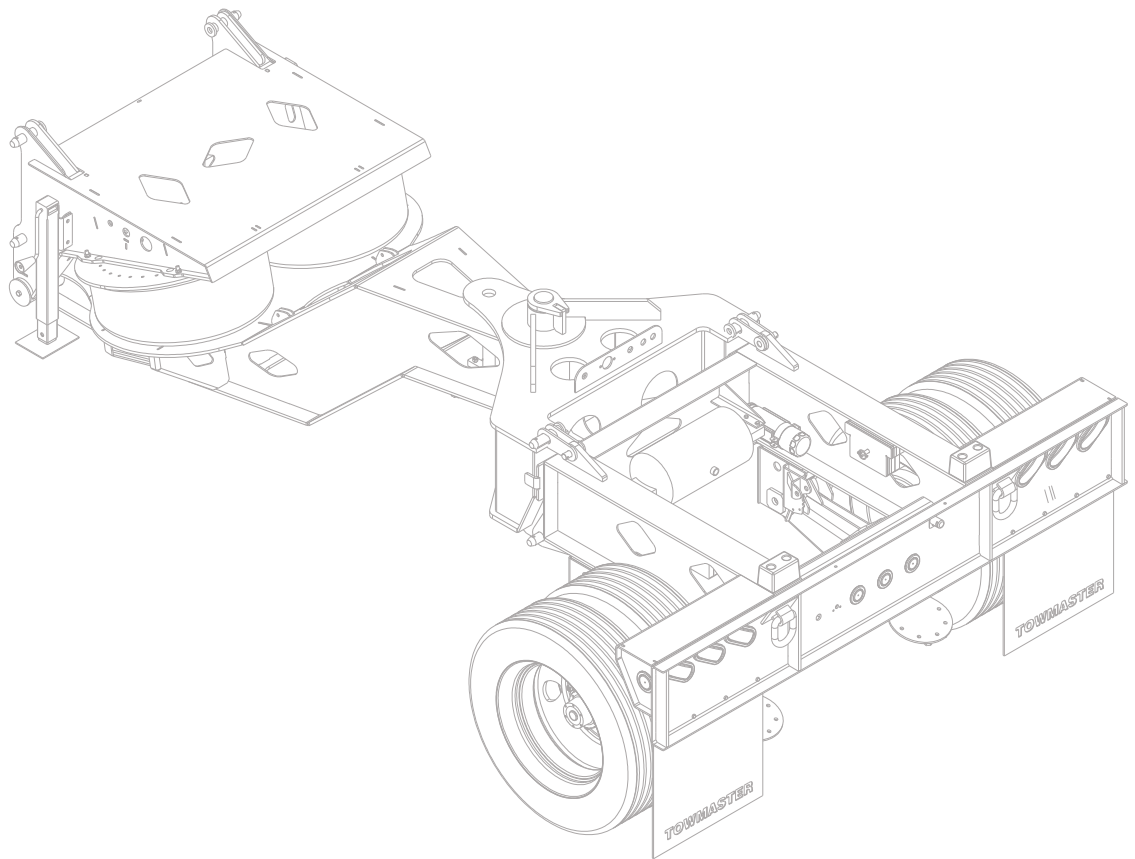

OPERATIONS

MAINTENANCE

SCHEMATICS

REPLACEMENT PARTS

## OPERATIONS

# OPERATIONS

OPERATIONS

- 1.1 Loading and Unloading
- 1.1 Backing with Stinger
- 1.2 Connect and Disconnect Flip Axle
- 1.3 Connect and Disconnect Stinger

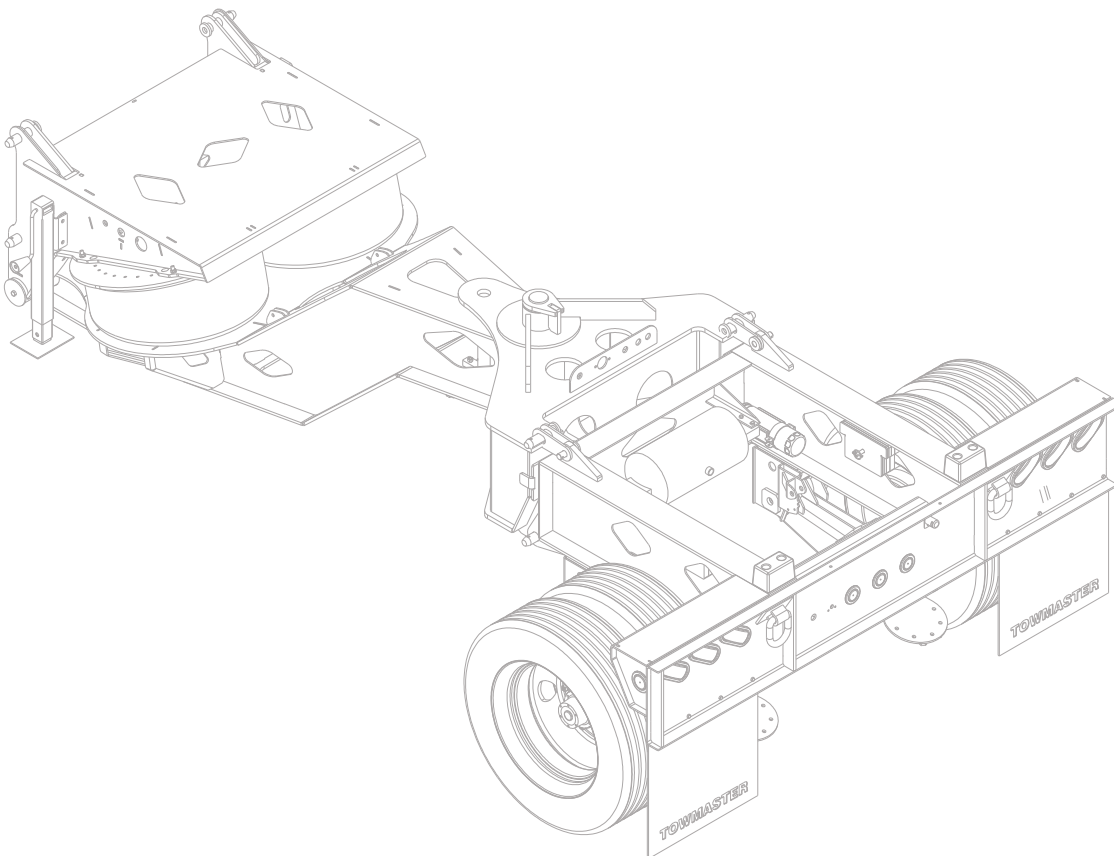

# Titanium Series Flip Axle & Stinger

## OPERATIONS

OPERATIONS

### Loading and unloading trailer

- 1) Pull out the stinger control valve when loading and unloading trailer. This will dump the air from the air bags on both the stinger and the flip axle.
- 2) Detach neck and load/unload trailer. Reattach neck and set deck height.
- 3) Check that flip axle control valve is in the stinger use mode.

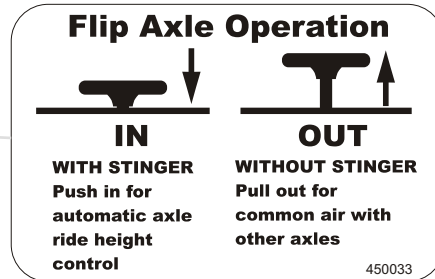

- 4) Adjust pressure control valve, prior to pushing in the stinger control valve, to approximately the desired air pressure. When trailer is empty do not exceed 15psi of stinger bag pressure. If stinger axle load is greater then trailer axle load loss of control may occur.



### Stinger Flip Axle Pressure/Weight Chart

Use as a guide ONLY. Weights and Pressures are approximate.

15 psi	– 5,000 lbs.
60 psi	– 10,500 lbs.
70 psi	– 13,700 lbs.
80 psi	– 14,500 lbs.
90 psi	– 17,500 lbs.
95 psi	– 19,000 lbs.
100 psi	– 20,000 lbs.

- 5) Push stinger control valve in. Wait for the air bags to fill and pressure to stabilize. This will take some time. Readjust as needed.

### Backing with Stinger

When backing trailer have stinger and trailer aligned. Pull stinger control valve out. This will deflate air bags and lift the pivot pin into lock position. When backing trailer with Stinger attached the Stinger Pivot Pin must be engaged so that the stinger does not pivot.

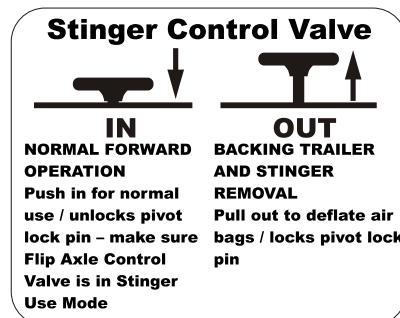

# Titanium Series Flip Axle & Stinger

## CONNECT/ DISCONNECT FLIP AXLE

Using flip axle on trailer. **Danger: Stay Clear of all Pinch Points**

- 1) Position flip axle on trailer tailboard and align lower mount holes. Install lower pins.
- 2) Pull out flip axle air dump valve.
- 3) Connect electrical plug, glad-hands and common air line.
- 4) (If equipped) set flip/stinger control valve to flip control.
- 5) Push in flip axle dump valve and inflate suspension.
- 6) Shim flip axle to obtain an axle clearance of 6.5" to 7.5". Readjust as load and trailer height change.

Flipping axle for non-use travel

- 1) Pull out flip axle air dump valve.
- 2) Remove shims.
- 3) Install upper mount pins
- 4) Disconnect electrical and air lines.
- 5) Remove lower mount pins. Axle may shift support flip and stay clear.
- 6) Attach chains to d-rings on back of flip. Lift and rotate flip axle on top of trailer by use of an overhead lifting source or min. capacity of 3,000lbs.

The Flip Axle and trailer must be on level ground. Back the trailer into the Flip Axle. The Flip Axle will need to be blocked up or a hoist will have to be used to hold the front of the Flip Axle for alignment. Once attached, store the Flip Axle by flipping it onto the rear of the trailer when not needed.

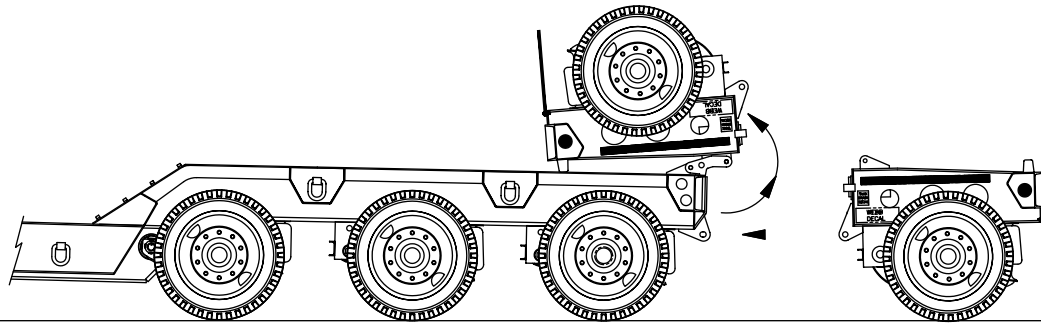

Align the bottom attachment holes and insert and secure the bottom pins. Allow the top of the Flip Axle to float.

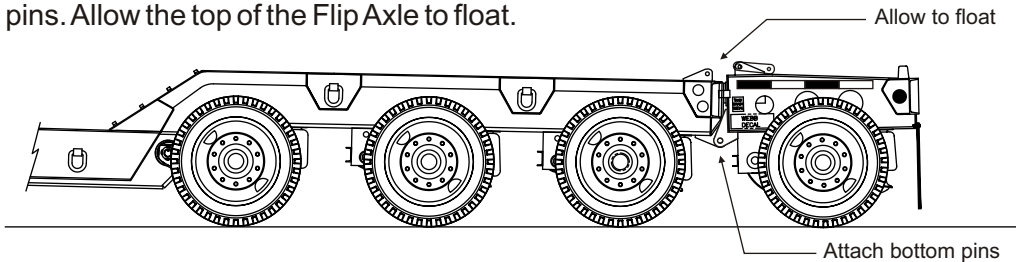

Use the shims to adjust the Flip Axle so that it rides level depending upon the trailer ride height and load carried. Start with the 1/4" shim and adjust as needed.

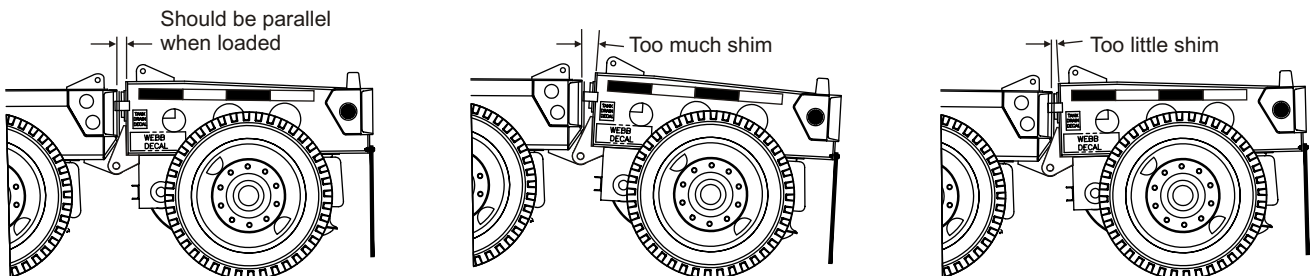



# Titanium Series Flip Axle & Stinger

## CONNECT/ DISCONNECT FLIP AXLE

When you want to store the Flip Axle on the rear of the trailer, insert and secure the top pins and remove the bottom pins. Use a loader or hoist to lift the Flip Axle and place on the trailer. Use the D-rings provided.



OPERATIONS

## CONNECT/ DISCONNECT STINGER

Using flip axle with stinger Note\*: Stinger will attach to the trailer in same procedure as the Flip Axle attached to the trailer. Refer to Flip Axle attachment instructions.

- 1) Position flip axle on rear of stinger. Align lower mount holes, install lower pins.
- 2) Shim flip so top of stinger and flip are parallel.
- 3) Connect electrical, glad-hands, orange and green lines.
- 4) Attach stinger to trailer. Refer to Flip axle attachment instructions.
- 5) Set flip/stinger control valve to stinger control.
- 6) Push in flip axle air dump valve.

### Operation Instructions

#### Connecting and Disconnecting Stinger

##### CONNECT

##### STAND CLEAR WHEN ALIGNING TRAILER TO STINGER

Pull out stinger control valve button

Use leveling jacks to align bottom pins (these must be installed before the top pins)

Install bottom pins

Use leveling jacks to align top pins (KEEP HANDS CLEAR OF PINCH POINTS)

Install top pins

Raise both jacks to highest position

Attach air hoses and electrical plug

Push in Stinger Control Valve button

##### DISCONNECT

Pull out Stinger Control Valve button

Remove electrical plug and air hoses

Lower both jacks to ground to support stinger

Remove top pins

Remove bottom pins

Drive trailer away from flexible stinger

450031

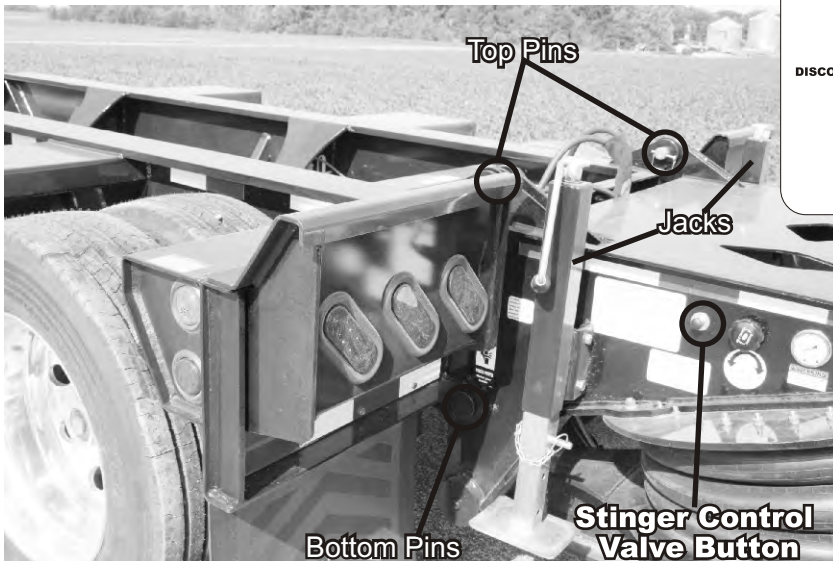

## MAINTENANCE

- 2.1 Air Spring Maintenance
- 2.2 Grease Points
- 2.2 Air Tank Water Trap
- 2.2 Glad Hands
- 2.2 Tire and Axle

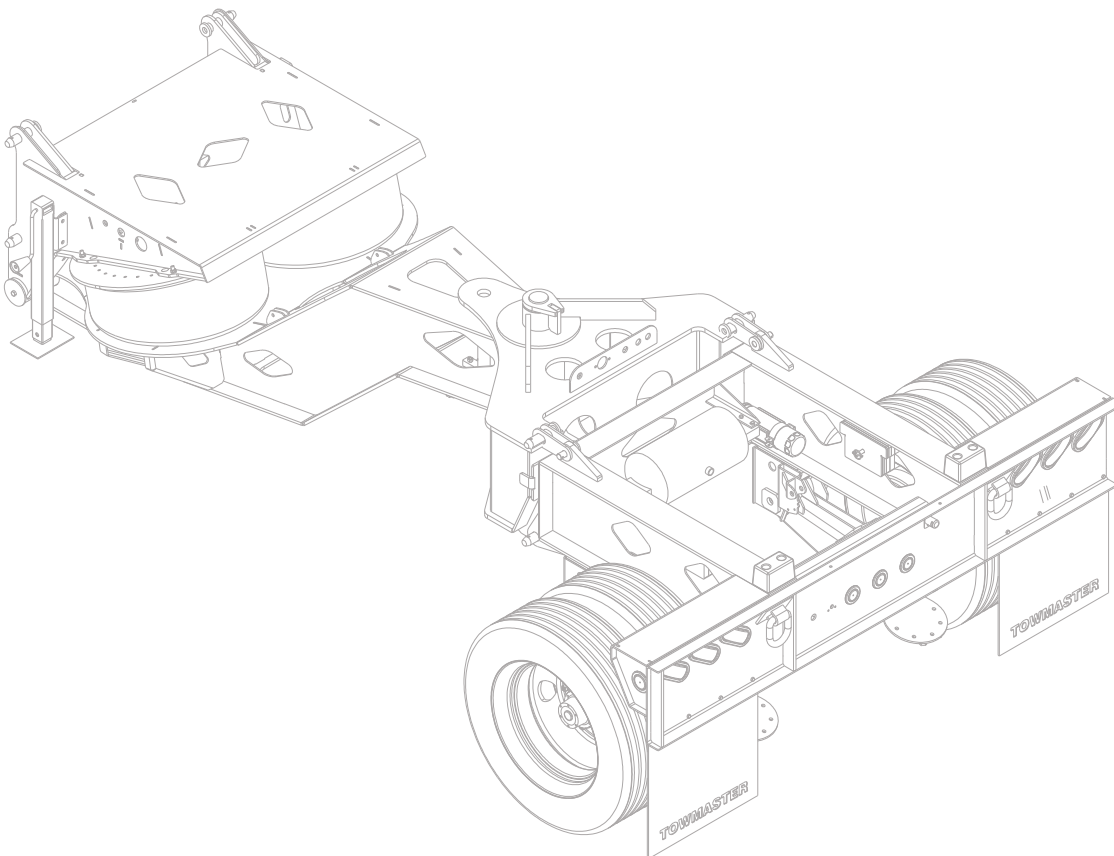

# Titanium Series Flip Axle & Stinger

## AIR SPRING MAINTENANCE

The air spring is an expensive and vital component of the Flexible stinger. Proper maintenance and care of the air spring will greatly increase its life.

### Cleaning:

On a regular basis check the large air spring on the stinger (Daily in muddy or dirty conditions). Remove any rocks sand or other debris from the air springs. (Check between the convolutes of the spring) Use soap and water to clean air springs. Do not use any organic solvents, petrochemical, open flames, abrasives, direct high pressure water or a direct pressurized steam cleaning system.

### Area surrounding the Air Spring:

Check the area around the air spring to make sure that nothing could rub against it and that at the

maximum diameter the air spring does not make contact with anything.

The temperature ranges for the air spring are as follows:

Standard construction: -34° to 134°F

### Inspect Surface:

Inspect the outer surface of the air spring. Check for uneven wear, cracks and damaged areas. Replace the air spring if needed.

### Inspect Pneumatic Components:

The air supply to the system plays a large role in the air springs' performance. Inspect, clean and replace if necessary any support products to the air springs, valves, regulators, air lines etc.

### Storage:

When not using the stinger it should be stored, as best as possible, in a cool, dry place with the air spring away from direct sunlight or ozone producing equipment.



# Titanium Series Flip Axle & Stinger

## GREASE POINTS

Grease points must be serviced before every days use. There are six grease zerks found upon the stinger. Refer to Fig.1 for those locations. Three pumps of grease or until grease is seen protruding from a relief area is the general rule of thumb. Multi- purpose Lithium based grease is recommended.

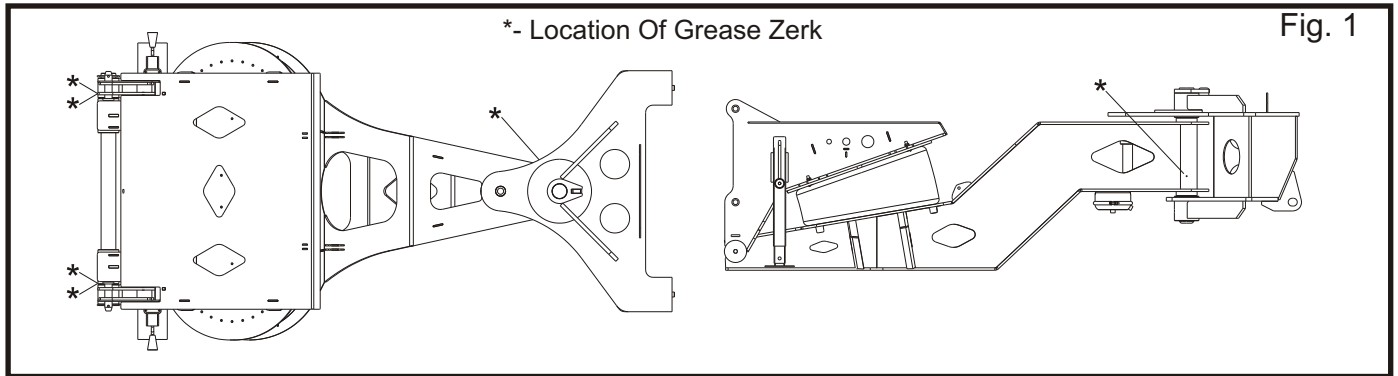

## AIR TANK WATER TRAP

The Air Tank found on the flip axle must be relieved after every days use (Fig.2). There is a bleeder cable attached to the frame on the drivers side in front of the wheels. Pull cable to release air/ water. Water condensation can accumulate within the water lines and will cause many problems during cold weather operation.

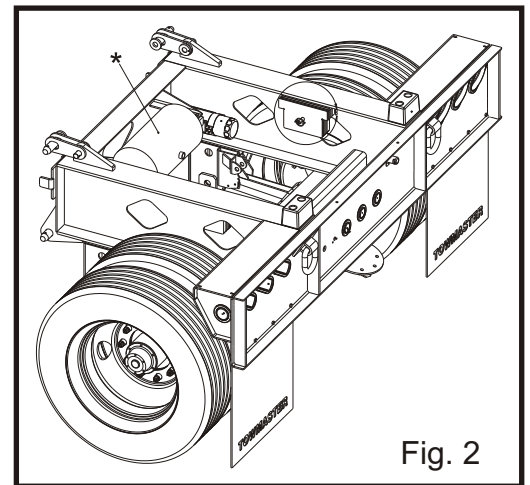

## GLAD HANDS

Glad Hands are the air supply hose ends. They must be clean at all times for proper operation of the air system. Properly place the Glad Hands in thier storage area whenever not in use. To properly clean a soiled Glad Hand remove the rubber and screen, wash with mild detergent and warm water, allow to dry thoroughly, and reinstall.

## TIRE and AXLE

Tire and Axle information can be found in the manufactures manual located in the registration tube where this manual was located. If any manual is missing refer to our website (found on back cover) to download the correct manual.

## SCHEMATICS

- 3.1 Flip Axle Air Schematic (Stinger Ready)
- 3.2 Flip Axle Air Schematic (Not Stinger Ready)
- 3.3 Stinger Air Schematic
- 3.4 Flip Axle Electrical Schematic

SCHEMATICS

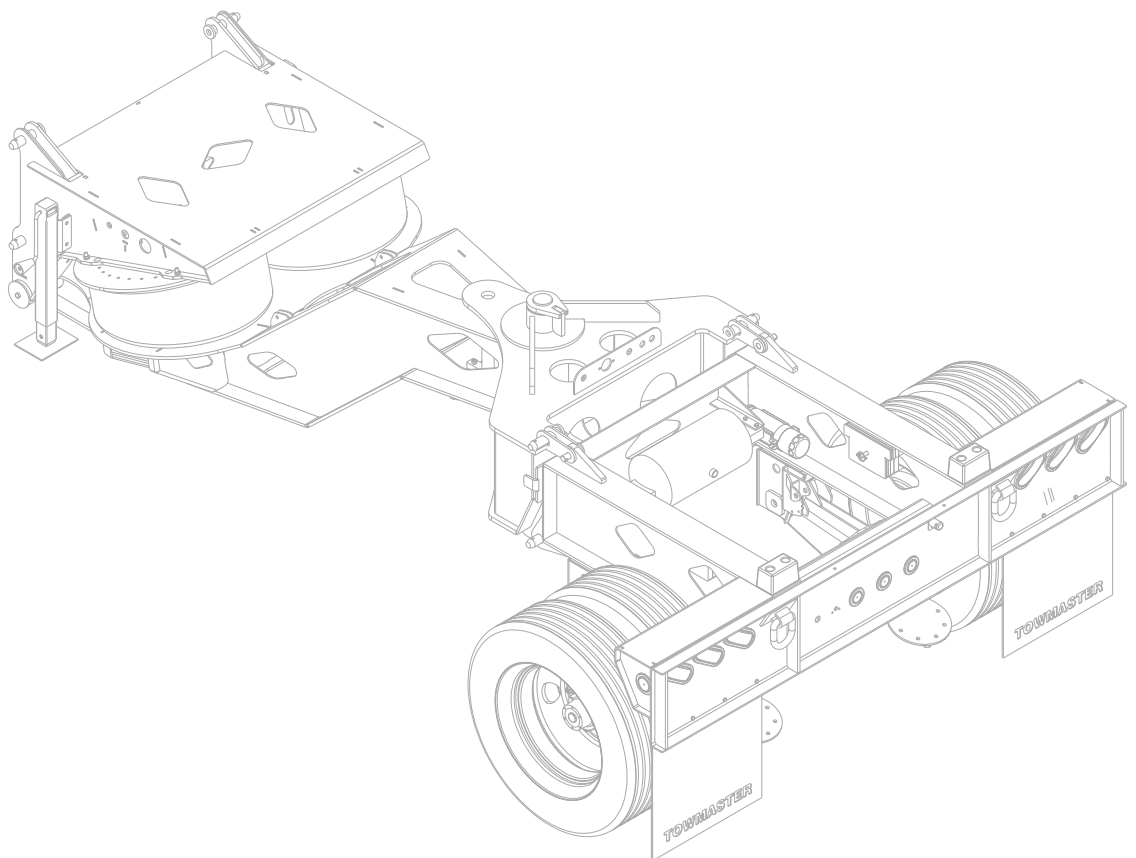

# Titanium Series Flip Axle & Stinger

## FLIP AXLE AIR SCHEMATIC (Stinger Ready)

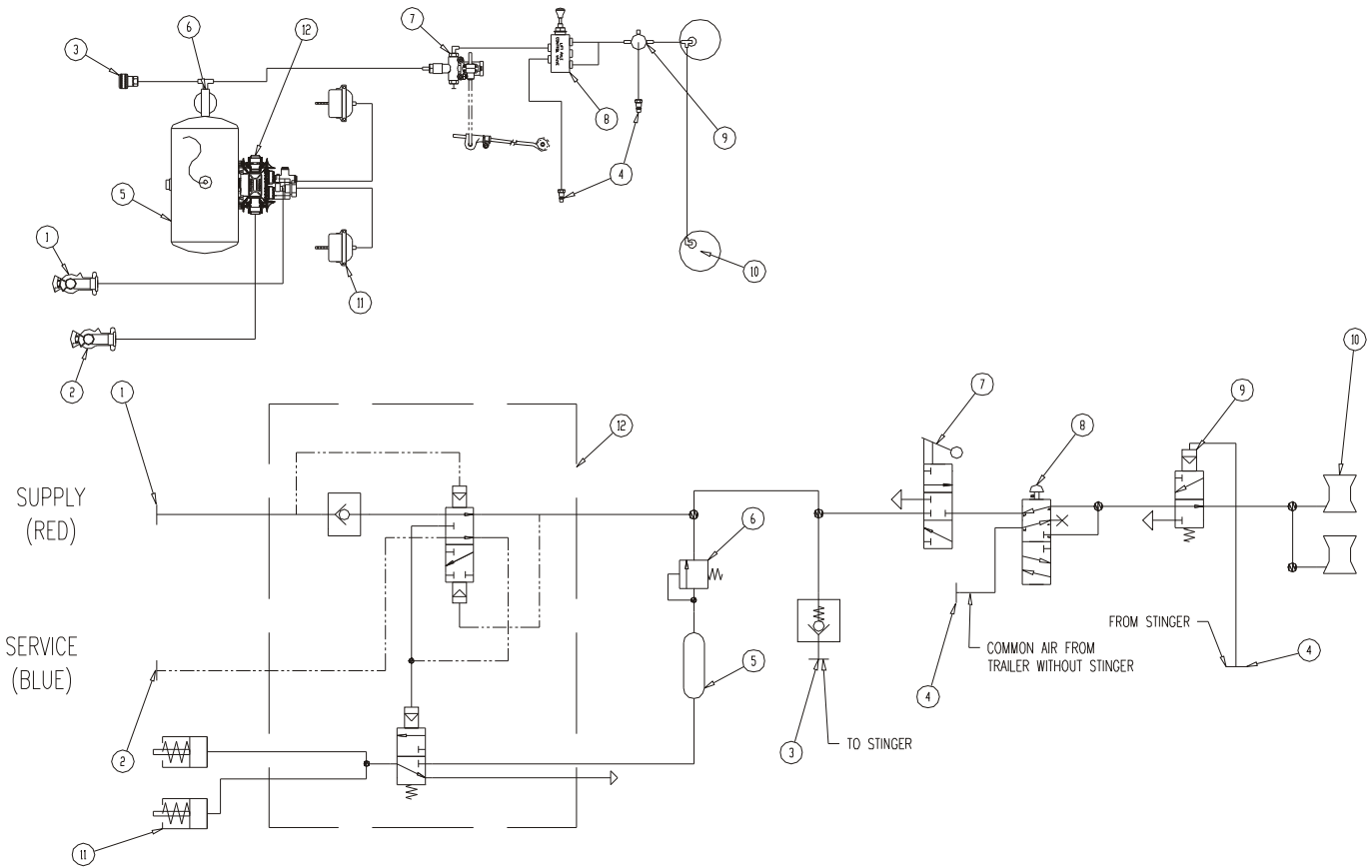

SCHEMATICS

Item	Part #	Description
1	35-0052	Emergency glad hand (red)
2	35-0050	Service glad hand (blue)
3	35-0926	Female quick connect
4	35-0927	Male quick connect
5	35-0080	Air tank, 1488ci.
6	37-0470	Valve pressure protection
7	37-0471	Ride height control valve
8	37-0907	Control valve
9	37-0475	Pilot valve
10	29-4056	Air spring
11	31-4510	Air chamber spring brake type 30
12	35-0227	Brake valve Sealco #110338









## REPLACEMENT PARTS

- 4.1 Stinger Replacement Parts
- 4.2 Flip Axle Replacement Parts
- 4.3 Flip Axle Decals
- 4.4 Stinger Decals

REPLACEMENT  
PARTS

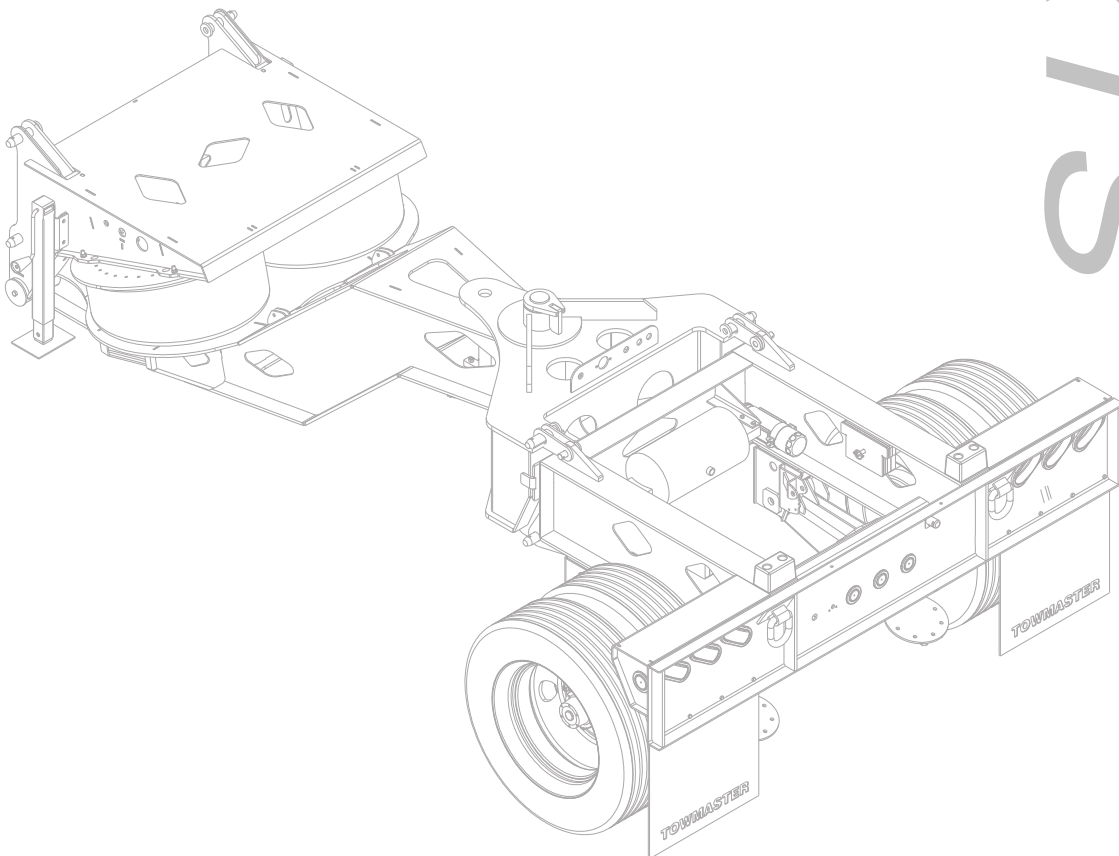

REPLACEMENT  
PARTS

# Titanium Series Flip Axle & Stinger

## STINGER REPLACEMENT PARTS

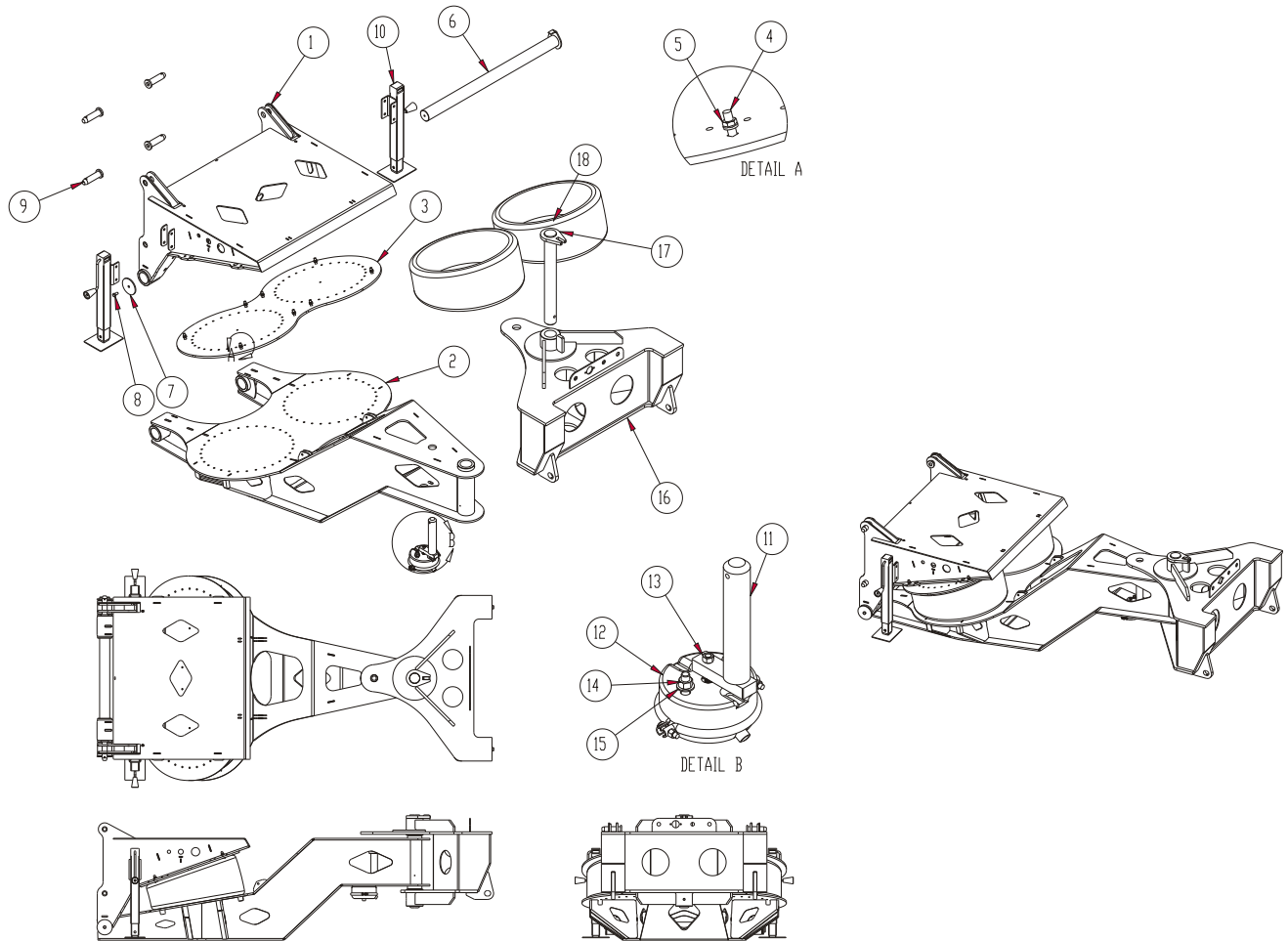

Item	Part #	Description
1	12-7009	Upper deck
2	12-7015	A-frame
3	12-7008	Upper bag mount
4	36-1008	Bolt
5	36-1015	Flange nut
6	12-7019	Pivot shaft
7	06-7984	Shaft end cap
8	36-080	Bolt
9	12-5176	Lower pin
10	12-7020	Jack assm.
11	12-6002	Lock pin weld.
12	31-4510	Air chamber
13	36-0060	Nut
14	36-0034	Nut
15	36-0406	Washer
16	12-5144	Pivot weld.
17	12-5146	Pivot pin
18	29-4145	Air spring

REPLACEMENT PARTS

# Titanium Series Flip Axle & Stinger

## FLIP AXLE REPLACEMENT PARTS

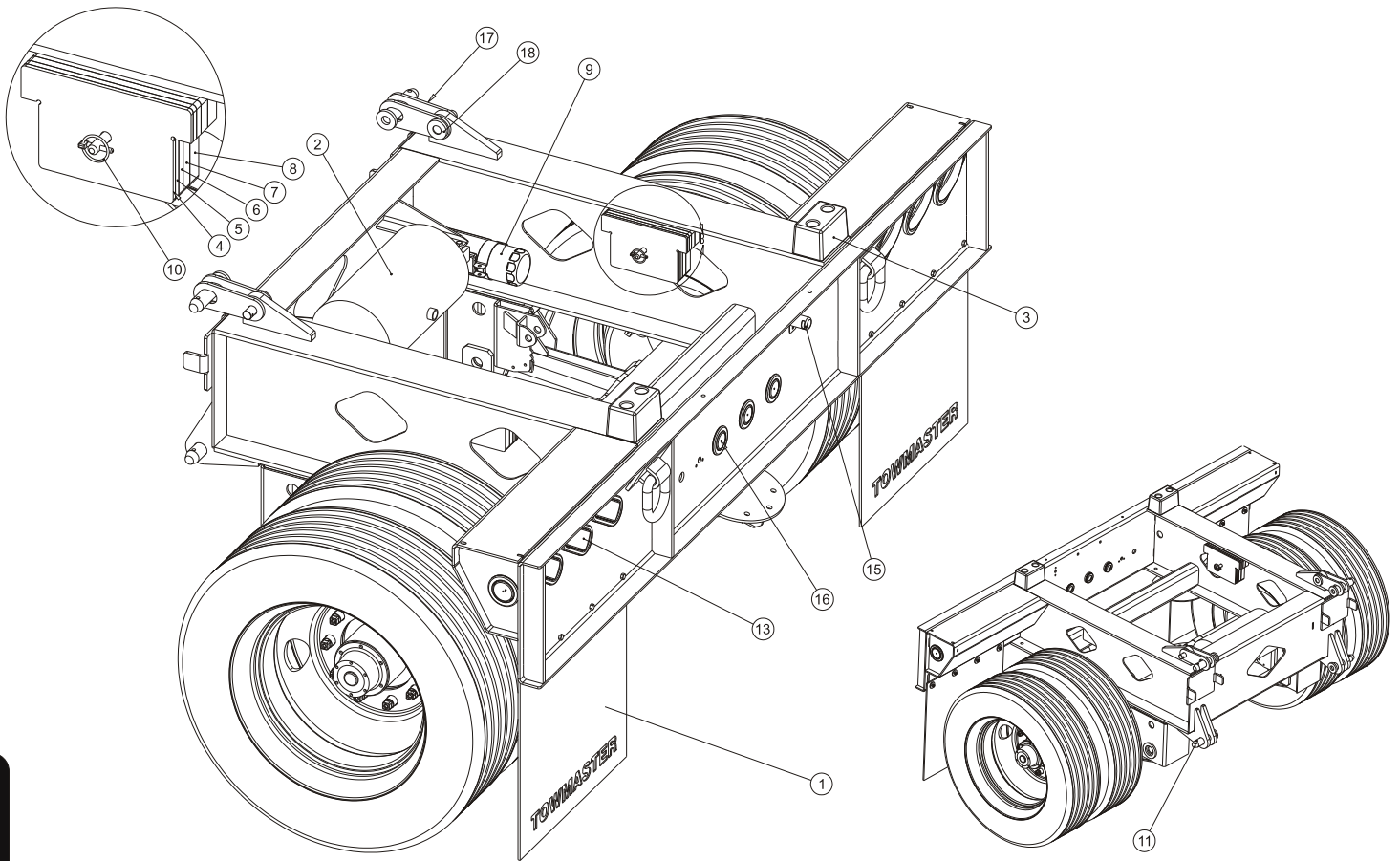

REPLACEMENT PARTS

Item	Part #	Description
1	37-0802	Towmaster Mud Flap
2	35-0080	Air Tank 6.44 gal.
3	37-0829	Rubber Bumper
4	06-5174	Shim, 1/4
5	06-5172	Shim, 3/8
6	06-5173	Shim, 1/2
7	06-5217	Shim, 3/4
8	06-5264	Shim, 1
9	37-6072	Registration Holder
10	37-3150	1/4" Lynch Pin w/chain
11	12-5176	Lower Pin
12	39-7048	Flip axle harness
13	39-3001, 3003	Light and grommet oval
14	39-3005, 3007	Light and grommet 2.5"
15	39-6241	License plate light
16	39-0304, 0086	Light and grommet 2" LED.
17	06-7003	Link top
18	12-6418	Pin







Portions of this manual were used with the expressed authority of Dexter Axle, but Dexter Axle is not responsible for the accuracy of the information contained herein.

Towmaster, Inc., 61381 U.S. Highway 12, Litchfield, MN 55355  
800-462-4517    Parts Dept. Fax: 320-693-5703  
[www.towmaster.com](http://www.towmaster.com)



Employee Owned  
Employee Pride  
U.S.A. Made!

Towmaster, Inc. offers a complete line of trailers from small pans and tilts to drop deck trailers to deck over models and large tilts and detachable gooseneck trailers. See your Towmaster Trailers dealer or visit our website to learn more. Manufacturer reserves the right to modify, without notice, specific designs and specifications as deemed advisable on the trailers described herein without obligation in regards to trailers previously sold. The manufacturer also reserves the right to discontinue any model or models without obligation in regards to trailers previously sold. Written warranty covers each trailer. No other warranty expressed or implied is made. Warranty on tires and brakes through original manufacturer. All dimensions approximate.